

**RoHS  
Compliant  
Drawing For  
Reference Only**

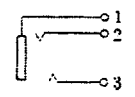
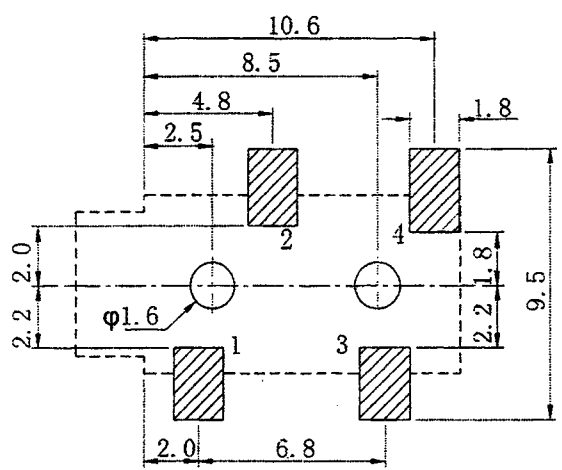
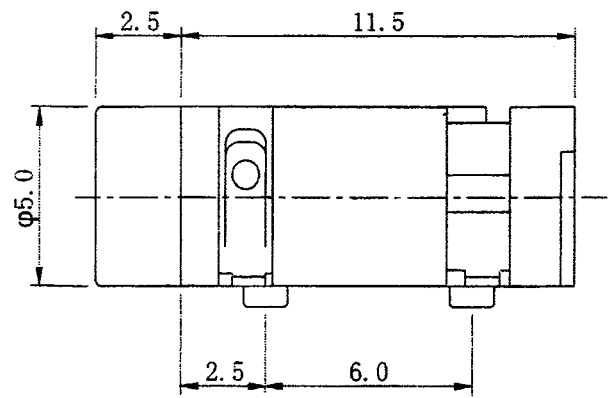
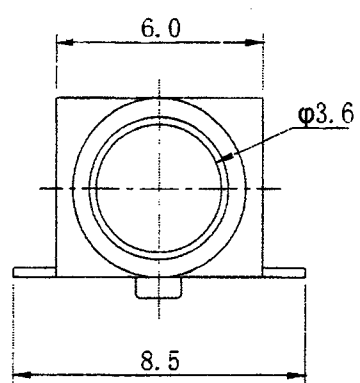

**Technical requirement :**

1. This product should meet EU RoHS related requirement.
2. The surface of plastic part should be without any crackle such as burr,lack,and so on phenomenon.
3. The surface of metal part should be without any defect such as scaur,nick,oxidation and plating problem.
4. The electronic performance should be the same as spec.
5. The un-specified tolerance is :  $< \pm 0.2$   
 $6 \sim 20 \pm 0.3$   
 $> 20 \pm 0.4$

**規格 Specifications**

額定負荷 Ratings	DC 30 V 0.5 A
絶縁電阻 Insulation Resistance	DC 500V 60 Sec. 100 m $\Omega$ Min
抗電強度 Dielectric Voltage	AC 500V (50~60Hz) 60 Sec.
操作力 Operating Force	挿入力 (Insertion Force) 3~20N
	抜出力 (Extraction Force) 3~20N
負荷寿命 Operating Life With Load	5,000 次 Cycles

**DCI DRAGON CITY INDUSTRIES LIMITED**

Item Name	3.5 MM PHONE JACK	Tolerance :
Item No.	ST-3008-02-TR(SL)	Unit : mm

Design	K.W Law	Remark		Scale	
Drawing	W.K Yeung	Remark		Material	
Check	K.L Wong	Remark		Drawing No.	A306191500
Approval	K.W Chan	Remark		Sheet	